

THERMISTOR SPECIFICATIONS

1) SCOPE

This specifications define rating, dimensions, insulation, climatic sequence and mechanical characteristics for AT type thermistor.

2) PART NO. : **203AT-2**

3) RATING

3-1) Rated zero-power resistance. R_{25} : 20 k Ω \pm 1 % (at 25 $^{\circ}$ C)

3-2) B value. $B_{25/85}$: 4,013 K \pm 1 %

* The B value is calculated using the zero-power resistance values measured at 25 $^{\circ}$ C and 85 $^{\circ}$ C.

3-3) Dissipation factor. : Approx. 2 mW/ $^{\circ}$ C (in air)

3-4) Thermal time constant. : Approx. 15 s (in air)

3-5) Maximum power rating. : 10 mW (at 25 $^{\circ}$ C)

3-6) Category temperature range : -50 ~ 110 $^{\circ}$ C

(= Operating temperature range)

4) DIMENSIONS

UNIT:[mm]

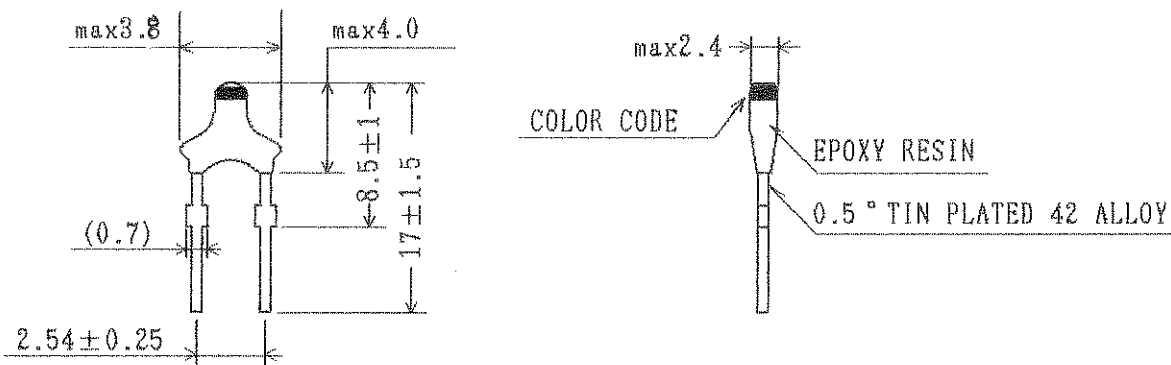

COLOR CODE : Nil

Spec.NO.: STANDARD-01		Note	REVISION	
Date: NOV.13,1992			A	
Approved	Checked	Drawn	B	
		K.KUMADA	C	
AT-01-20		1/3		NSSP-AT-212

5) INSULATION

5-1) Insulation resistance

Insulation resistance of the test samples shall be over 100 MΩ when it is measured at DC 500V between coated area and lead wires.

6) CLIMATIC SEQUENCE

6-1) Dry heat

After the test samples were exposed in air at 90 °C for 1,000 hours, the change ratio of the rated zero-power resistance shall be within $\pm 1\%$ of the initial value.

6-2) Damp heat

After the test samples were exposed in the humidity of 95% at 70°C for 1,000 hours, the change ratio of the rated zero-power resistance shall be within $\pm 1\%$ of the initial value.

6-3) Cold

After the test samples were exposed in air at -55°C for 1,000 hours, the change ratio of the rated zero-power resistance shall be within $\pm 1\%$ of the initial value.

6-4) Humidity load

After DC 1mA current was applied to the test samples in the temperature of 70°C and the humidity of 95% for 1,000 hours, the change ratio of the rated zero-power resistance shall be within $\pm 1\%$ of the initial value.

6-5) Change of temperature

One cycle of the change of temperature shall be carried out in the order of the following conditions.

- Room ambient temperature. (Initial value)
- At -30°C , for 30 minutes.
- Room ambient temperature, for 3 minutes.
- At $+90^{\circ}\text{C}$, for 30 minutes.
- Room ambient temperature. for 3 minutes.

After 100 cycles of change of temperature, the change ratio of the rated zero-power resistance shall be within $\pm 1\%$ of the initial value.

AT THERMISTOR		STANDARD
AT-00-10	2/3	NSSP-AT-120

7) MECHANICAL CHARACTERISTICS

7-1) Robustness of terminations

Ua: Tensile

After 0.2 kgf loading weight for 3 seconds was applied to the wire terminations, there shall be no visible damage.

7-2) Free fall

After one time natural fall to a maple board from 1 m high, there shall be no visible damage.

7-3) Resistance to soldering heat

After lead wire of the test samples were dipped one time within 8.5 mm from end of lead wire in solder bath at $260^{\circ}\text{C} \pm 10^{\circ}\text{C}$ for 10 ± 0.5 seconds, the change ratio of the rated zero-power resistance shall be within $\pm 1\%$ of the initial value.

AT THERMISTOR

STANDARD

AT-00-**

3/3

NSSP-AT-130